

Fahrzeug-Zustandsbericht

Vehicle condition report

ID Nummer/ ID Number	Ankunftsort/ Place of Arrival
Model/ Type	Kennzeichen/ Licence Number
Chassis Nummer/ Chassis Number	Abfahrtsdatum/ Date of Departure
Abfahrtsort/ Place of Departure	Ankunftsdatum/ Date of Arrival

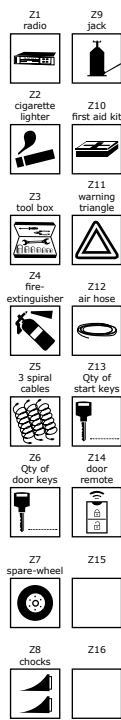
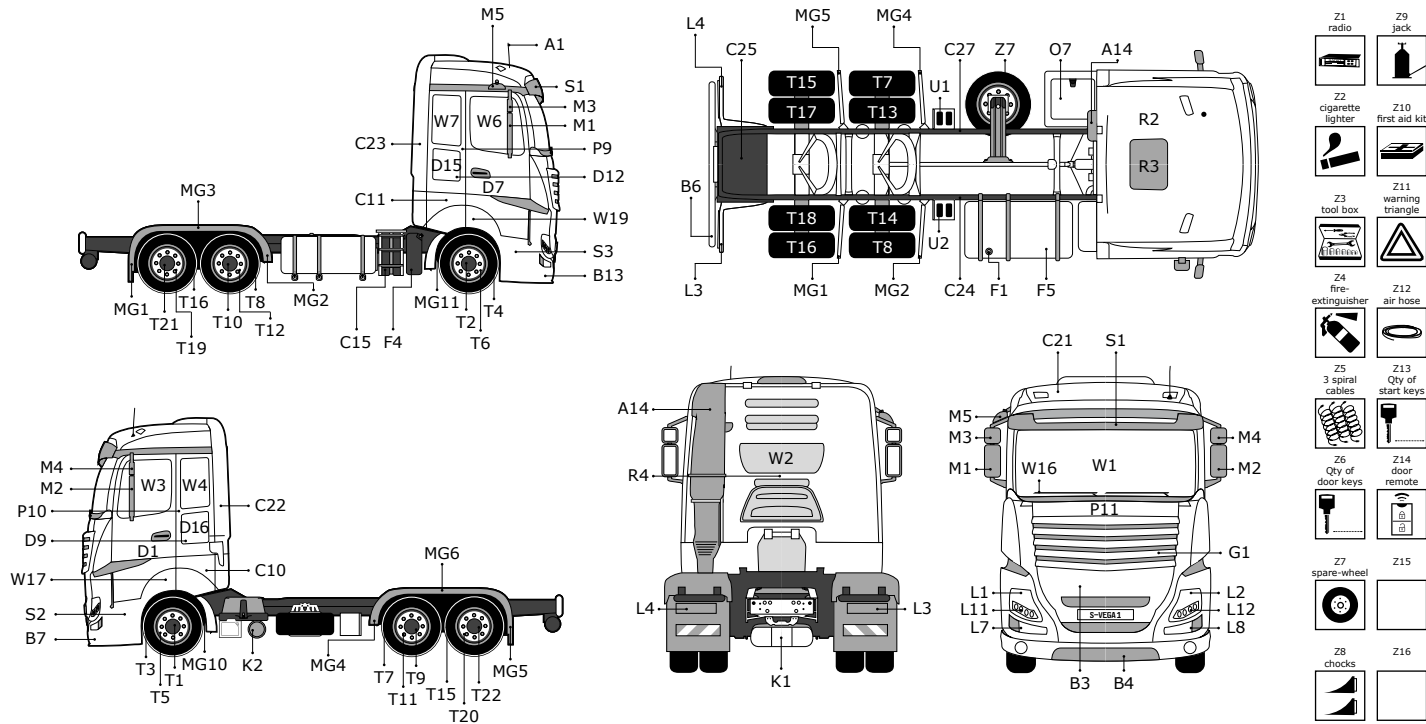

Damage codes	Beschädigungscodes	Dommage code	Codici danni	Hasar kodlari	код повреждения
0= OK	0= OK	0= OK	0= OK	0= OK	0= ок
1= missing	1= fehlt	1= manquer	1= manca	1= eksik	1= отсутствует
2= scratch	2= Kratzer	2= griffure	2= graffio	2= cizik	2= царапина
3= broken	3= gebrochen	3= cassée	3= rotto	3= kirik	3= сломанный
4= dent	4= Delle	4= concave	4= concavo	4= centik	4= вмятина
5= cut	5= Schnitt	5= décaupage	5= tagilo	5= kesik	5= порез
6= cracked	6= Sprung	6= crevasse	6= crepato	6= catlak	6= трещина
7= damaged	7= beschädigt	7= dommage	7= danno	7= hasar	7= повреждение
8= factory fault	8= Fabrikationsfehler	8= défaut de fabrication	8= difetto di fabbrica	8= Fabrika hatasi	8= производственный брак

Zustand bei/ condition at	festgestellt von/ noted by	Codes, Stelle, Schaden, Ausmaß/ Codes, position, damage, size	Unterschrift, Stempel/ signature, stamp	Name/name
1 Beladung/loading	Transport Firma/ transport company			
2 Fahrerwechsel/ driver change	Transport Firma/ transport company			
3 Abgangshafen/ port departure	Agent-Abgangshafen/ agent			
4 Schiffsabfahrt/ vessel departure	Verschiffungslinie/ shipping line			
5 Schiffsankunft/ vessel arrival	Verschiffungslinie/ shipping line			
6 Ankunftshafen/ port arrival	Agent-Ankunftshafen/ agent			
7 Zustellung/ delivery	Empfänger/receiver			
Bemerkungen/remarks				

Fahrzeug-Zustandsbericht

Vehicle condition report

ID Nummer/ ID Number	Ankunftsort/ Place of Arrival
Model/ Type	Kennzeichen/ Licence Number
Chassis Nummer/ Chassis Number	Abfahrtsdatum/ Date of Departure
Abfahrtsort/ Place of Departure	Ankunftsdatum/ Date of Arrival

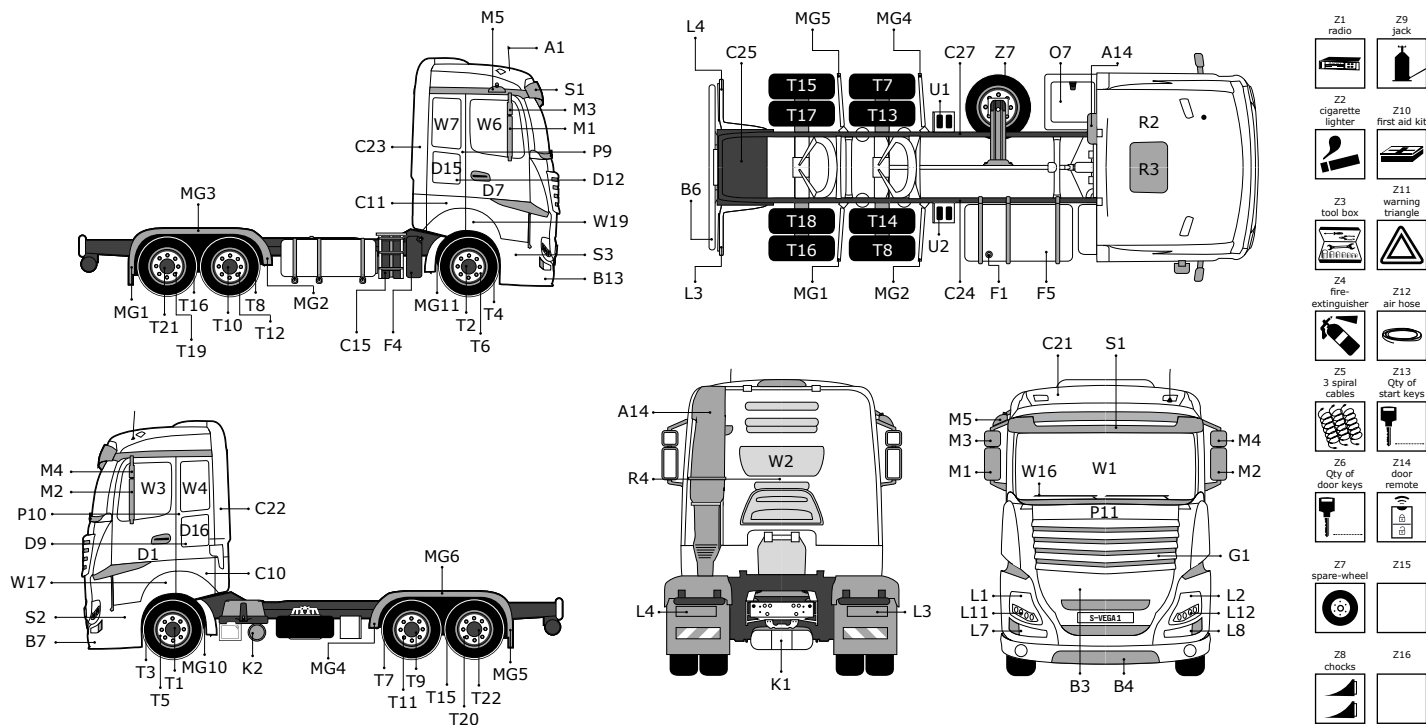

- Z1 radio
- Z2 cigarette lighter
- Z3 tool box
- Z4 fire extinguisher
- Z5 3 spiral cables
- Z6 Qty of door keys
- Z7 spare-wheel
- Z8 checks
- Z9 jack
- Z10 first aid kit
- Z11 warning triangle
- Z12 air hose
- Z13 Qty of start keys
- Z14 door remote
- Z15
- Z16

Damage codes	Beschädigungscodes	Dommage code	Codici danni	Hasar kodlari	код повреждения
0= OK	0= OK	0= OK	0= OK	0= OK	0= ок
1= missing	1= fehlt	1= manquer	1= manca	1= eksik	1= отсутствует
2= scratch	2= Kratzer	2= griffure	2= graffio	2= cizik	2= царапина
3= broken	3= gebrochen	3= cassée	3= rotto	3= kirik	3= сломанный
4= dent	4= Delle	4= concave	4= concavo	4= centik	4= вмятина
5= cut	5= Schnitt	5= décaupage	5= tagilo	5= kesik	5= порез
6= cracked	6= Sprung	6= crevasse	6= crepato	6= catlak	6= трещина
7= damaged	7= beschädigt	7= dommage	7= danno	7= hasar	7= повреждение
8= factory fault	8= Fabrikationsfehler	8= défaut de fabrication	8= difetto di fabbrica	8= Fabrika hatasi	8= производственный брак

Zustand bei/ condition at	festgestellt von/ noted by	Codes, Stelle, Schaden, Ausmaß/ Codes, position, damage, size	Unterschrift, Stempel/ signature, stamp	Name/name
1 Beladung/loading	Transport Firma/ transport company			
2 Fahrerwechsel/ driver change	Transport Firma/ transport company			
3 Abgangshafen/ port departure	Agent-Abgangshafen/ agent			
4 Schiffsabfahrt/ vessel departure	Verschiffungslinie/ shipping line			
5 Schiffsankunft/ vessel arrival	Verschiffungslinie/ shipping line			
6 Ankunftshafen/ port arrival	Agent-Ankunftshafen/ agent			
7 Zustellung/ delivery	Empfänger/receiver			
Bemerkungen/remarks				